

REV	DATE	REVISION RECORD	REF
7	7-11-07	ADDED HOPPER SUPPORT, CHANGED TO LARGER DIA. WASHER (HOPPER SUPPORT). ADDED OPTIONAL MANUAL HOLDER	B.C.P.

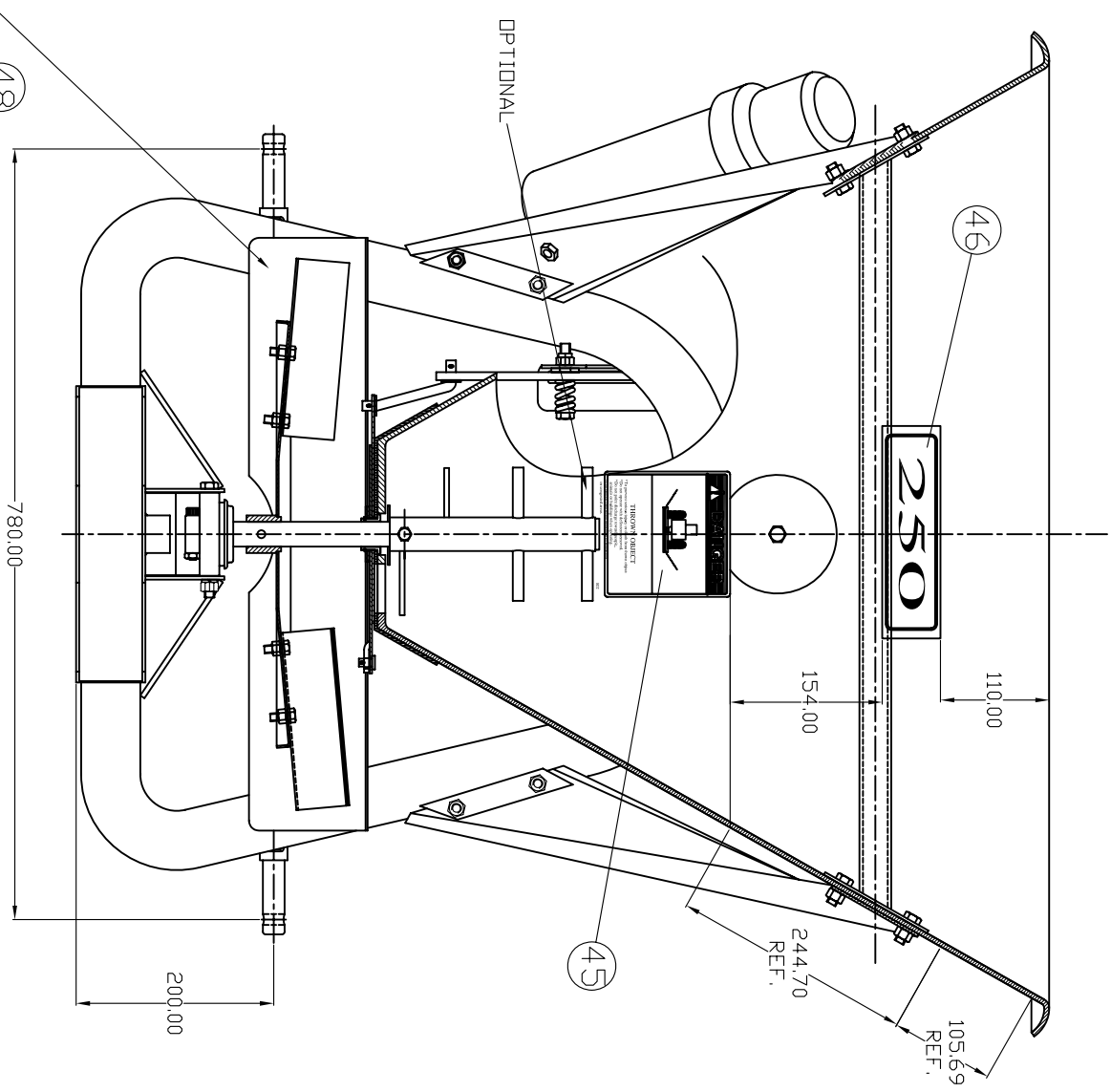
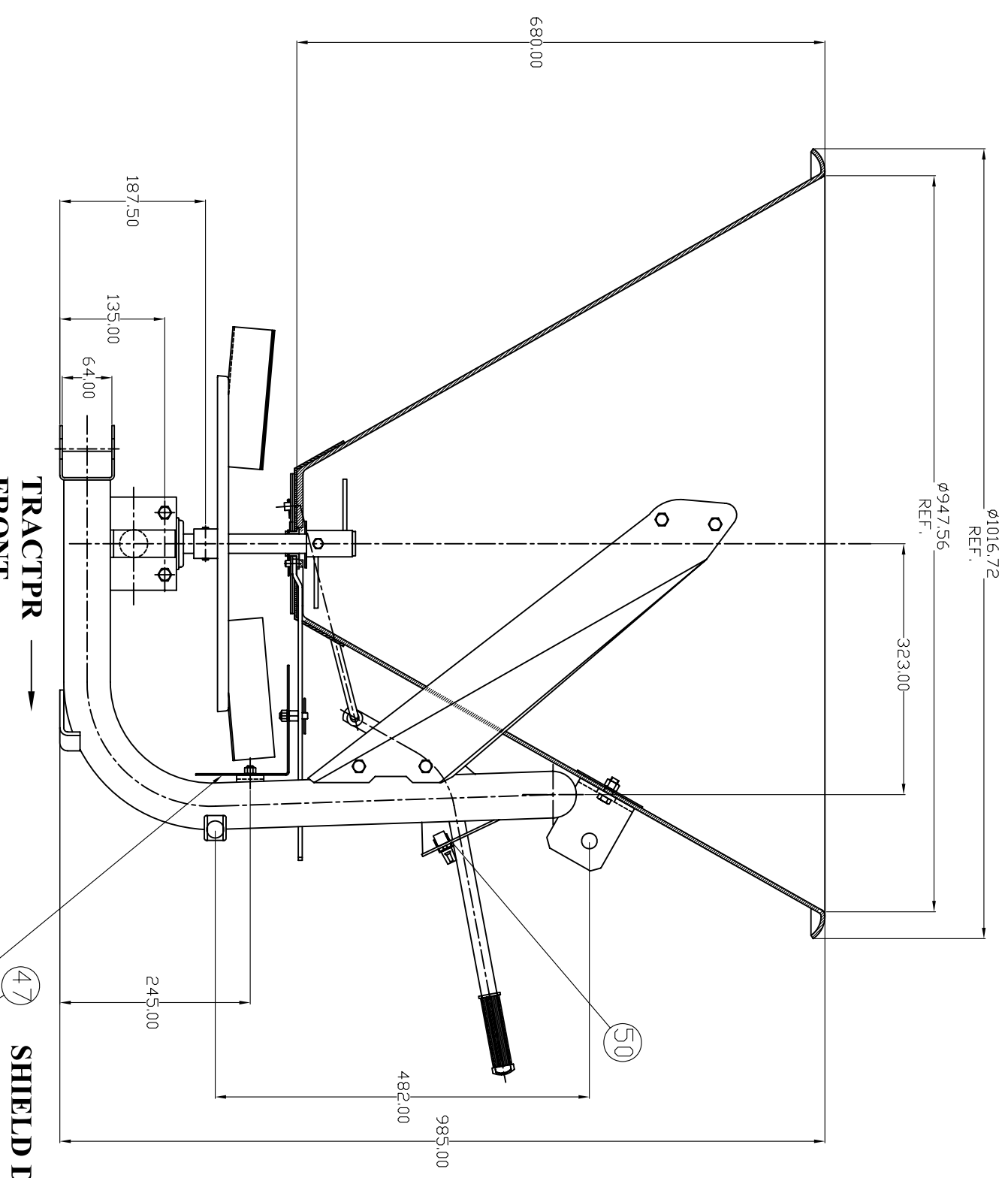

TRACTPR  
FRONT

TOP VIEW

SHIELD DECAL  
LOCATIONS

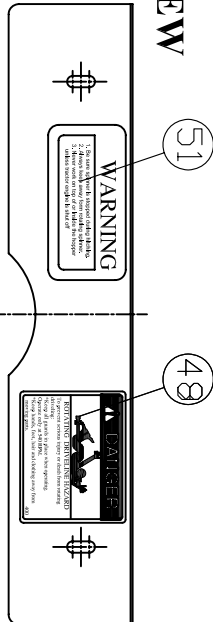
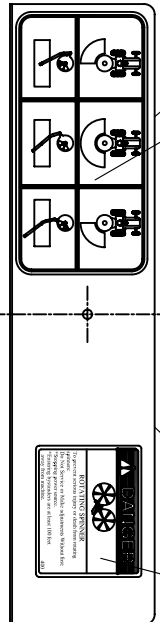

**NOTES:**

1. MATERIAL:
2. WEIGHT: KG W/D DRIVELINE

<p><b>INTERNATIONAL TECHNOLOGY GROUP</b></p>		<p>ENG. OFFICE: Edi V. Trull, Sr. P.D., Box 1698 Dodge Dr., KS 67201 Tel: (620) 227-5453 Fax: (620) 227-7213</p>	
		<p>SALES OFFICE: 5375 Avenida Encinas, Suite F Carlsbad, CA 92008 Tel: (760) 431-3644 Fax: (760) 431-8889</p>	
<p>TOLERANCES (EXCEPT AS NOTED)</p>		REFERENCE NUMBER	SCALE
DECIMAL	FRACTIONAL		1=1
±0.25	±	TITLE	DRAWN BY
ANGULAR	MACHINE FINISH	ITG SPREADER 250 LITER	B.C.P.
±	3.2	DATE	APPROVED BY
		08-29-05	
		PART NUMBER	REVISION
		32-041	7

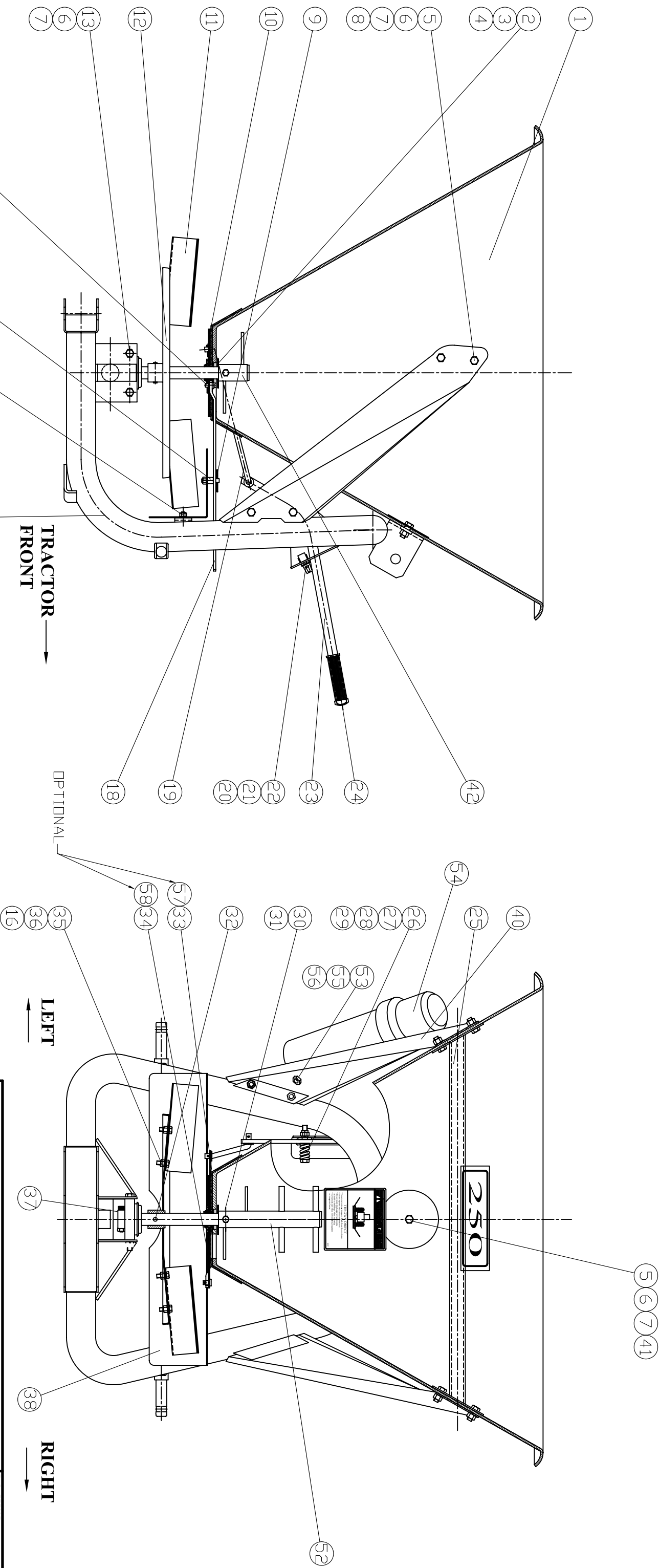

**NOTES:**

1. MATERIAL:
2. WEIGHT: KG, W/D DRIVE LINE

<b>ITG</b>		<b>INTERNATIONAL TECHNOLOGY GROUP</b>	
TOLERANCES (EXCEPT AS NOTED)		REFERENCE NUMBER	SCALE
DECIMAL	FRACTIONAL		1=1
±0.25	±	TITLE	
ANGULAR	MACHINE FINISH	ITG SPREADER 250 LITER	
±	3.2	DATE	PART NUMBER
	✓	09-27-06	32-041
			REVISION
			7

ENG. OFFICE: 201 W. Trail St.-P.O. Box 1698  
 Dodge City, KS 67801  
 Tel: (620) 237-2463  
 Fax: (620) 237-7215

SALES OFFICE: 5375 Avenida Encinas, Suite F  
 Carlsbad, CA 92008  
 Tel: (760) 431-3646  
 Fax: (760) 431-8889

DRAWN BY: B.C.P.  
 APPROVED BY:



# INTERNATIONAL TECHNOLOGY GROUP

ENG. OFFICE:  
201 W Trail St.-P.O. Box 1698  
Dodge City, KS 67801  
Tel: (620) 227-2463  
Fax: (620) 227-7215

SALES OFFICE:  
5375 Avenida Encinas, Suite F  
Carlsbad, CA 92008  
Tel: (760) 431-3644  
Fax: (760) 431-8889

TITLE

ITG SPREADER 250 LITER

PART NUMBER

32-041

SHEET: 3 OF 6

DATE

09-26-06

REFERENCE NUMBER

REVISION

7

DRAWN BY:

B.C.P.

SCALE: NTS

APPROVED BY:

DET.	PART NO.	QTY.	DESCRIPTION
1	19-311	1	SPREADER 250 LITER HOPPER
2	04-131	1	RETAINER BUSHING
3	07-088	1	ø11.0xø100.0x3.0 HOPPER SUPPORT WASHER
4	21-040	1	RETAINING RING
5	06-063	10	M10 x 1.5 x 25 HEX HEAD BOLT
6	11-005	14	M10 x 1.5 HEX HEAD NUT
7	07-001	14	ø10 SPLIT TYPE LOCKWASHER
8	07-015	14	ø10 x ø20 x2 FLAT ZINC PLATED WASHER
9	12-048	2	ø2 HAIR PIN
10	12-050	2	COTTER PIN
11	19-291	4	SPREADER DISTRIBUTOR VANE
12	19-292	1	SPREADER DISC
13	06-096	3	M10x1.5x108.6 HEX BOLT
14	06-103	1	SPREADER SHUTTER ADJUSTMENT PIVOT JOINT
15	12-055	1	SPREADER LEVER, FIXED PIVOT
16	11-045	11	M8 x 1.25 HEX HEAD NUT
17	16-153	1	SPREADER BASE ASSEMBLY
18	19-299	1	SPREADER DIRECTIONAL LEVER
19	19-287	1	SPREADER TIE ROD
20	06-094	1	SPREADER THUMB SCREW
21	19-308	1	SPREADER GAGE POINTER
22	19-307	1	SPREADER THREADED ADJ. BLOCK
23	19-286	1	SPREADER LEVER
24	19-298	1	SPREADER LEVER, RUBBER GRIP
25	16-152	1	SPREADER HOPPER SUPPORT ASSEMBLY
26	19-306	1	SPREADER SPRING
27	11-014	1	M10-DIN-985 NYLON LOCKING NUT
28	06-099	1	M10x1.5x70 HEX BOLT
29	07-087	1	ADJUSTMENT LEVER WASHER
30	06-097	1	M8x.25x50 HEX HEAD BOLT
31	11-046	1	NYLON LOCKING NUT
32	12-049	1	2 ø8 x 40 ROLL PIN
33	19-301	1	SPREADER TOP SHUTTER PLATE (FLOW CONTROL)
34	19-300	1	SPREADER BOTTOM SHUTTER PLATE (DIRECTIONAL)
35	06-095	10	M8x1.25x20 HEX HEAD BOLT
36	07-075	11	ZINC PLATED FLAT WASHER
37	01-429	1	201 F/G 1:1 - SPREADER DRIVE
38	19-296	1	SPREADER FRONT SHIELD
39	19-294	1	RIGHT SIDE HOPPER SUPPORT ARM
40	19-312	1	LEFT SIDE HOPPER SUPPORT ARM W/ MANUAL HOLDER
41	07-074	1	ø10xø30x3.0 FLAT WASHER



# INTERNATIONAL TECHNOLOGY GROUP

ENG. OFFICE:  
201 W Trail St.-P.O. Box 1698  
Dodge City, KS 67801  
Tel: (620) 227-2463  
Fax: (620) 227-7215

SALES OFFICE:  
5375 Avenida Encinas, Suite F  
Carlsbad, CA 92008  
Tel: (760) 431-3644  
Fax: (760) 431-8889

TITLE ITG SPREADER 250 LITER

PART NUMBER  
32-041

SHEET: 4 OF 6

DATE

09-26-06

REFERENCE NUMBER

REVISION

7

DRAWN BY: B.C.P.

SCALE: NTS

APPROVED BY:

DET.	PART NO.	QTY.	DESCRIPTION
42	19-295	1	SINGLE PIECE AGITATOR (SHORT)
43	07-090	1	Ø24.85xØ60.0x3.0 NYLON WASHER
44	19-398	1	ITG SPREADER HOPPER SUPPORT PAN
<b>SPREADER DECALS</b>			
45	19-090	1	THROWN OBJECT WARNING DECAL
46	13-081	1	SIZE DECAL
47	13-082	1	DIRECTIONAL DECAL
48	13-079	1	SPINNER WARNING DECAL
49	13-014	1	DRIVE SHAFT WARNING DECAL
50	13-084	1	GAGE DECAL
51	13-078	1	WARNING DECAL

## OPTIONAL ITG SPREADER PARTS

### OPTIONAL SINGLE PIECE AGITATORS

52	19-290	1	SINGLE PIECE EXTENDED AGITATOR (LONG)
<b>OPTIONAL MANUAL HOLDER AND HARDWARE</b>			
53	11-045	3	M8x1.25 HEX NUT
54	01-473	1	ITG MINI MANUAL HOLDER
55	06-095	3	M8x1.25x20 HEX HEAD BOLT
56	07-075	3	ZINC PLATED FLAT WASHER
<b>OPTIONAL STAINLESS STEEL SHUTTERS</b>			
57	19-284	1	ITG SPREADER TOP SHUTTER PLATE-STAINLESS STEEL
58	19-288	1	ITG SPREADER BOTTOM SHUTTER PLATE-STAINLESS STEEL

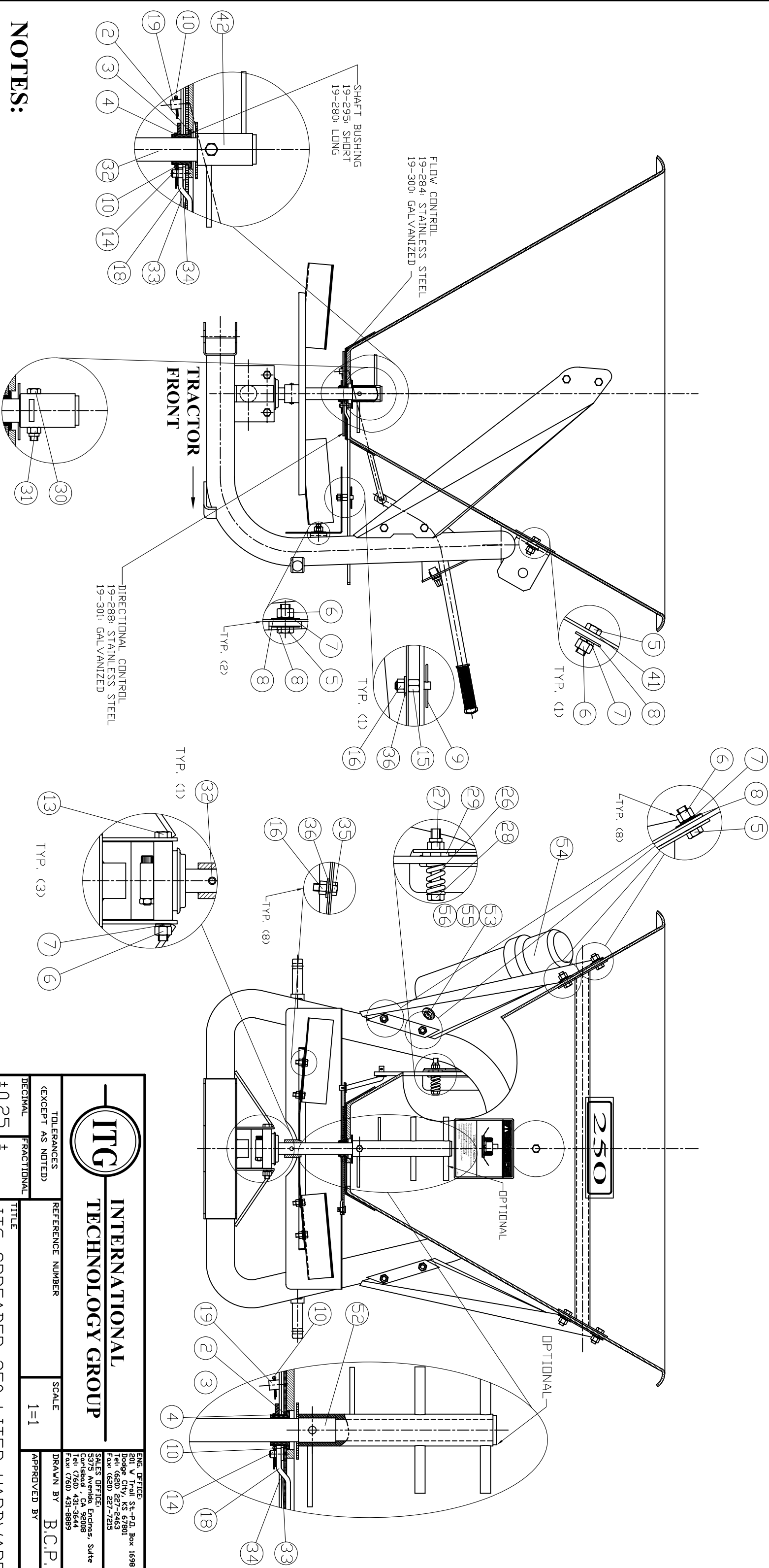

- NOTES:**
1. MATERIAL:
  2. WEIGHT: 45.5 Kg W/D DRIVELINE

		<b>INTERNATIONAL TECHNOLOGY GROUP</b>		ENG. OFFICE: 201 W. Trail St.-P.O. Box 1698 Dodge City, KS 67801 Tel: (620) 237-2463 Fax: (620) 237-7213	
		SALES OFFICE: 5375 Avenida Encinas, Suite F Carlsbad, CA 92008 Tel: (760) 431-3646 Fax: (760) 431-8889		DRAWN BY <b>B.C.P.</b>	
TOLERANCES (EXCEPT AS NOTED)		REFERENCE NUMBER	SCALE 1=1	APPROVED BY	
DECIMAL ±0.25	FRACTIONAL ±	TITLE <b>ITG SPREADER 250 LITER-HARDWARE</b>			
ANGULAR ±	MACHINE FINISH 3.2	DATE 09-26-06	PART NUMBER 32-041	REVISION 7	



# INTERNATIONAL TECHNOLOGY GROUP

ENG. OFFICE:  
201 W Trail St.-P.O. Box 1698  
Dodge City, KS 67801  
Tel: (620) 227-2463  
Fax: (620) 227-7215

SALES OFFICE:  
5375 Avenida Encinas, Suite F  
Carlsbad, CA 92008  
Tel: (760) 431-3644  
Fax: (760) 431-8889

TITLE  
ITG SPREADER 250 LITER-HARDWARE KIT BAG

PART NUMBER  
32-041

SHEET: 6 OF 6

DATE

09-26-06

REFERENCE NUMBER

REVISION

7

DRAWN BY: B.C.P.

SCALE: NTS

APPROVED BY:

## ALL ITEMS LISTED BELOW ARE STANDARD ITEMS PACKED IN THE HARDWARE KIT BAG

DET.	PART NO.	QTY.	DESCRIPTION
2	04-131	1	ITG RETAINER BUSHING
3	07-088	1	Ø11.0xØ100.0x3.0 HOPPER SUPPORT WASHER
4	21-040	1	RETAINING RING
5	06-063	10	M10 x 1.5 x 25 HEX HEAD BOLT
6	11-005	14	M10 x 1.5 HEX HEAD NUT
7	07-001	14	Ø10 SPLIT TYPE LOCKWASHER
8	07-015	14	Ø10 x Ø20 x2 FLAT ZINC PLATED WASHER
9	12-048	2	Ø2 HAIR PIN
10	12-050	2	COTTER PIN
11	19-291	4	ITG SPREADER DISTRIBUTOR VANE
14	12-055	1	ITG SPREADER SHUTTER ADJUSTMENT PIVOT JOINT
15	06-103	1	ITG SPREADER LEVER, FIXED PIVOT
16	11-045	11	M8 x 1.25 HEX HEAD NUT
18	19-299	1	ITG SPREADER DIRECTIONAL LEVER
19	19-287	1	ITG SPREADER TIE ROD
20	06-094	1	ITG SPREADER THUMB SCREW
21	19-308	1	ITG SPREADER GAUGE POINTER
22	19-307	1	ITG SPREADER THREADED ADJ. BLOCK
23	19-286	1	ITG SPREADER LEVER
24	19-298	1	ITG SPREADER LEVER, RUBBER GRIP
26	19-306	1	ITG SPREADER SPRING
27	11-014	1	M10-DIN-985 NYLON LOCKING NUT
28	06-099	1	M10x1.5x70 HEX BOLT
29	07-087	1	ITG ADJUSTMENT LEVER FIBER WASHER
30	06-097	1	M8x.25x50 HEX HEAD BOLT
31	11-046	1	NYLON LOCKING NUT
32	12-049	1	2 Ø8 x 40 ROLL PIN
35	06-095	10	M8x1.25x20 HEX HEAD BOLT
36	07-075	11	ZINC PLATED FLAT WASHER
41	07-074	1	Ø10xØ30x3.0 FLAT WASHER
42	19-295	1	SINGLE PIECE AGITATOR (SHORT)
43	07-090	1	Ø24.85xØ60.0x3.0 NYLON WASHER