

REV	DATE	REVISION RECORD	REF
7	7-11-07	ADDED HOPPER SUPPORT, CHANGED TO LARGER DIA. WASHER (HOPPER SUPPORT). ADDED OPTIONAL MANUAL HOLDER	B.C.P.

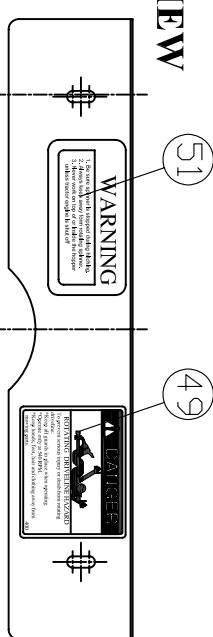
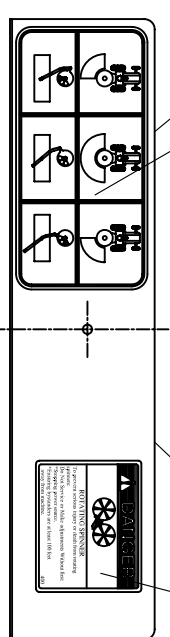
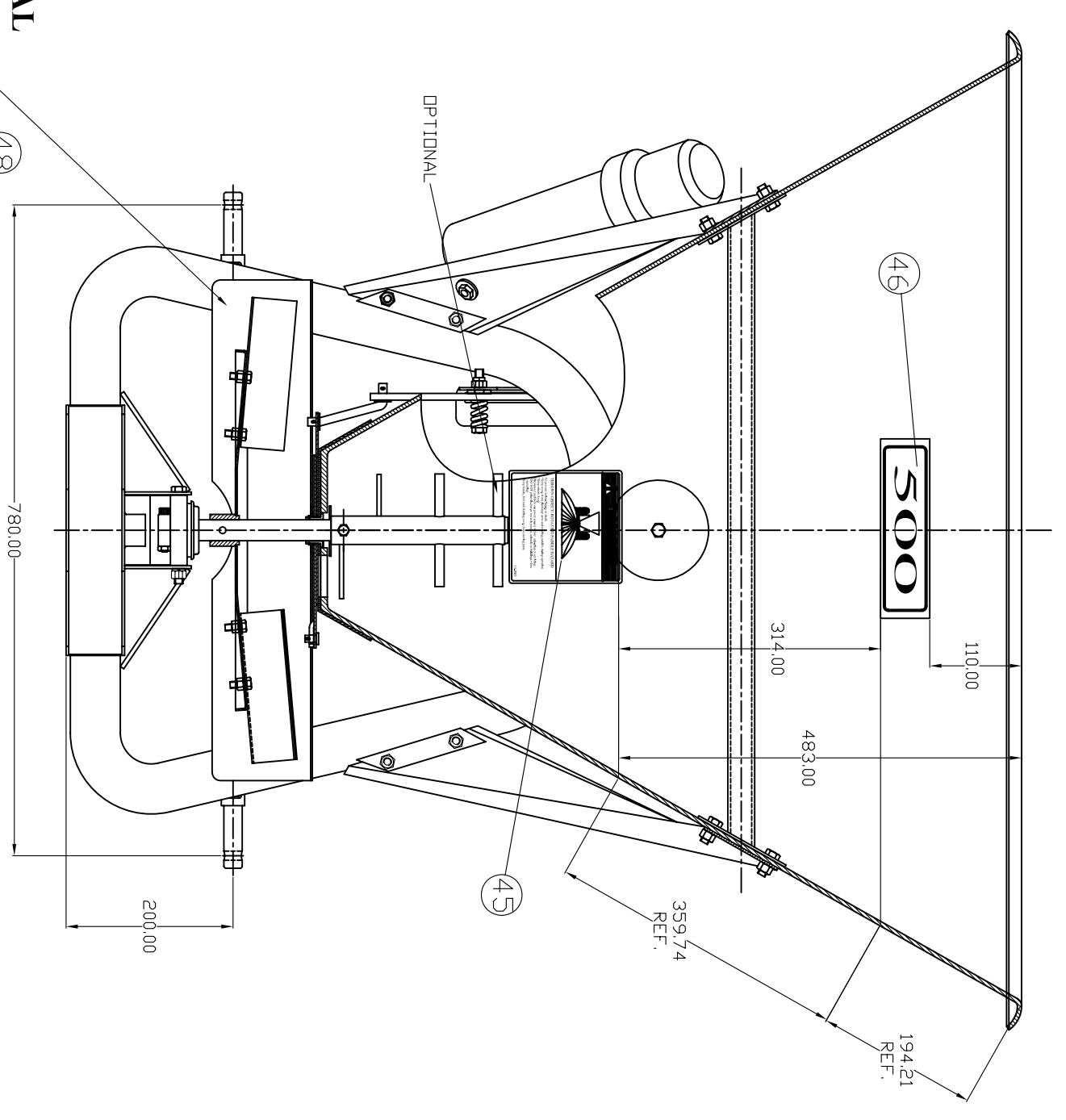
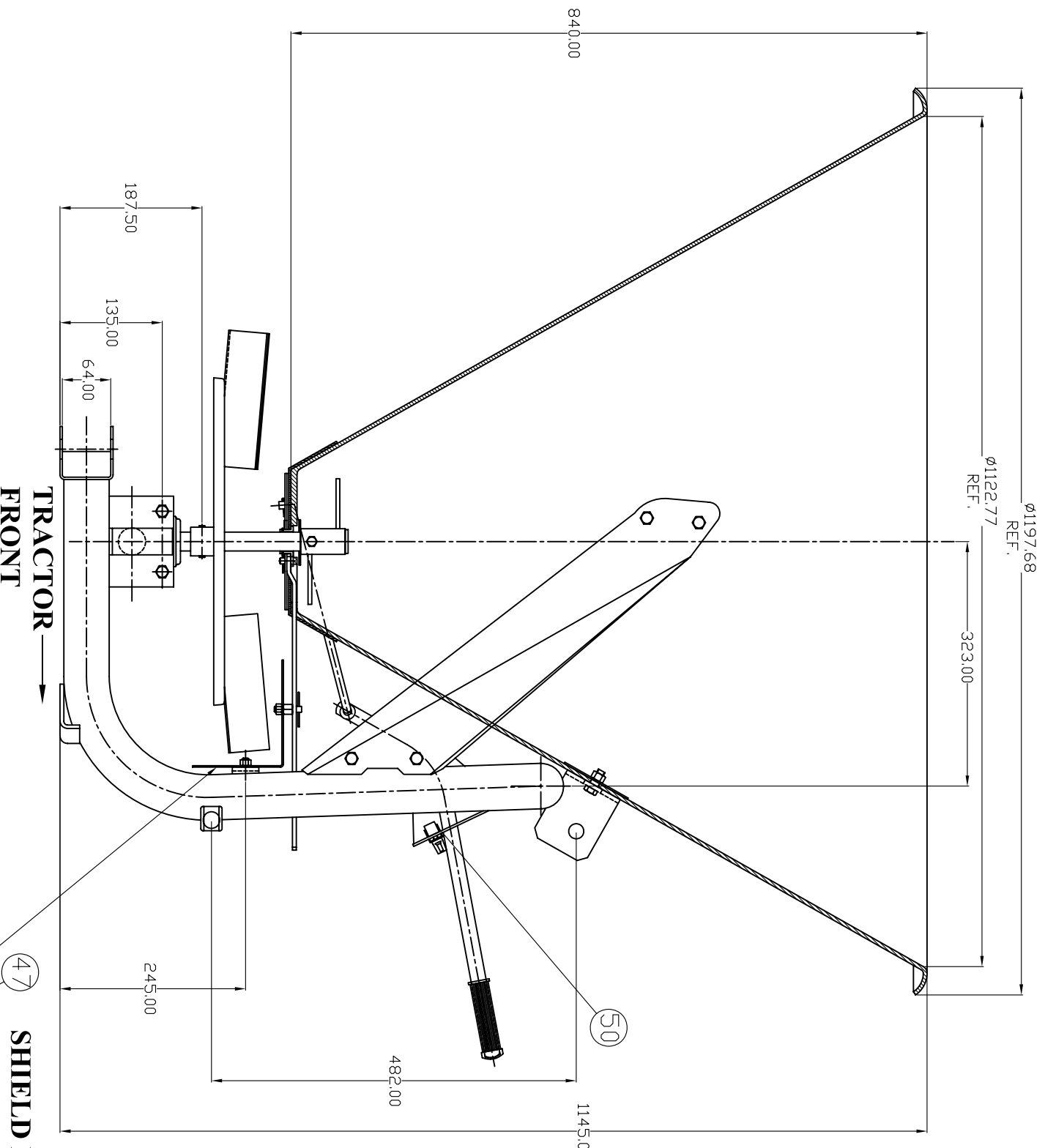

NOTES:

1. MATERIAL:
2. WEIGHT: 45.5 KG W/D DRIVE LINE

		INTERNATIONAL TECHNOLOGY GROUP		ENG. OFFICE: Ed1, W. Trail St.-P.O. Box 1698 Dodge D17, KS 67201 Tel: (620) 227-5453 Fax: (620) 227-7213	
		SALES OFFICE: 5375 Avenida Encinas, Suite F Carlsbad, CA 92008 Tel: (760) 431-3644 Fax: (760) 431-8889		DRAWN BY: B.C.P. APPROVED BY:	
TOLERANCES (EXCEPT AS NOTED) DECIMAL ±0.25 FRACTIONAL ± ANGULAR ± 3.2°		REFERENCE NUMBER	SCALE 1=1	TITLE ITG SPREADER 500 LITER	
DATE 09-26-06		PART NUMBER 32-040	REVISION 7		REF. B.C.P.

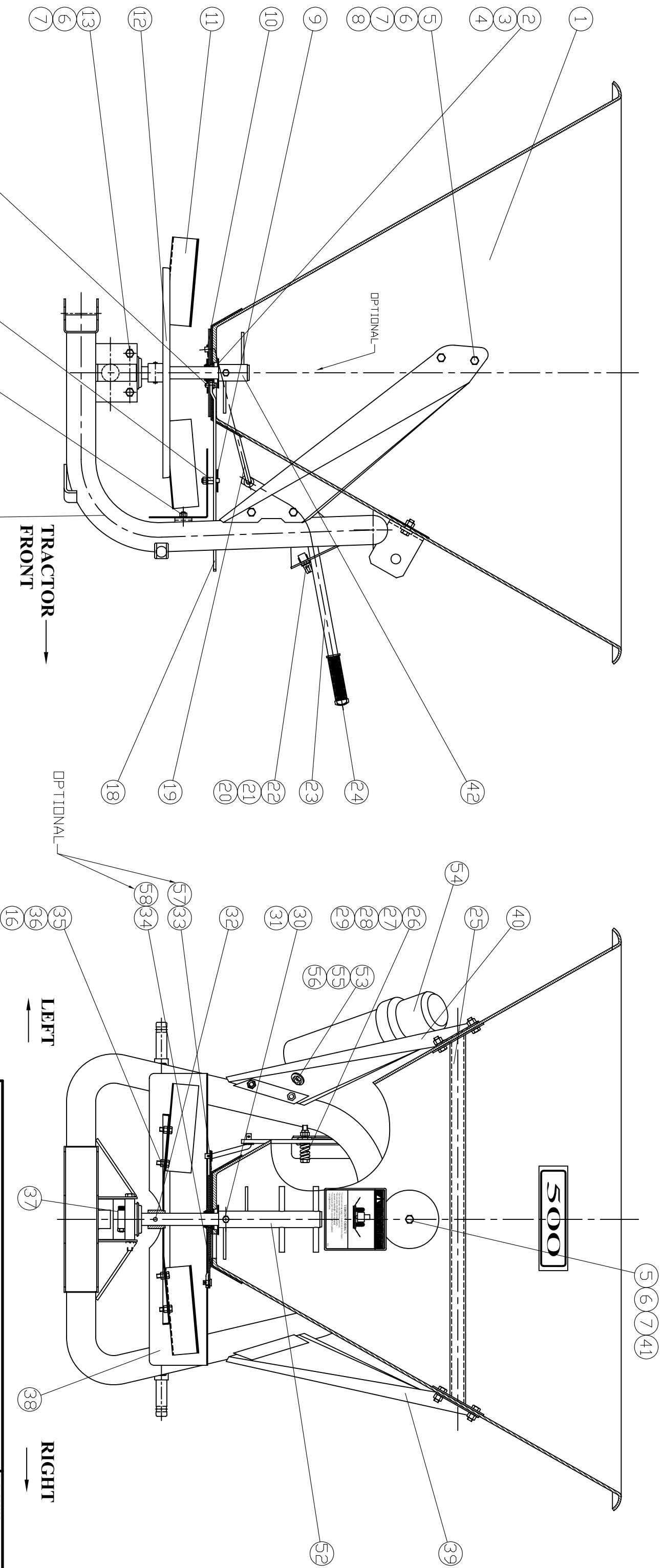

NOTES:

1. MATERIAL:
2. WEIGHT: 45.5 KG, W/D DRIVE LINE

		INTERNATIONAL TECHNOLOGY GROUP		<small>ENG. OFFICE: 201 W. Trail St.-P.O. Box 1698 Joplin City, KS 67801 Tel: (650) 627-2463 Fax: (650) 627-7215</small>	
		<small>SALES OFFICE: 5375 Avenida Encinas, Suite F Carlsbad, CA 92008 Tel: (760) 431-3646 Fax: (760) 431-8889</small>		<small>DRAWN BY APPROVED BY</small>	
<small>TOLERANCES (EXCEPT AS NOTED)</small>		<small>REFERENCE NUMBER</small>	<small>SCALE</small>	<small>DRAWN BY</small>	
<small>DECIMAL</small>	<small>FRACTIONAL</small>		1=1	B.C.P.	
±0.25	±	ITG SPREADER 500 LITER			
<small>ANGULAR</small>	<small>MACHINE FINISH</small>	<small>DATE</small>	<small>PART NUMBER</small>	<small>REVISION</small>	
±	3.2	09-26-06	32-040	7	



INTERNATIONAL TECHNOLOGY GROUP

ENG. OFFICE:
201 W Trail St.-P.O. Box 1698
Dodge City, KS 67801
Tel: (620) 227-2463
Fax: (620) 227-7215

SALES OFFICE:
5375 Avenida Encinas, Suite F
Carlsbad, CA 92008
Tel: (760) 431-3644
Fax: (760) 431-8889

TITLE ITG SPREADER 500 LITER

PART NUMBER
32-040

SHEET: 3 OF 6

DATE

09-26-06

REFERENCE NUMBER

REVISION

7

DRAWN BY: B.C.P.

SCALE: NTS

APPROVED BY:

DET.	PART NO.	QTY.	DESCRIPTION
1	19-310	1	ITG SPREADER 500 LITER HOPPER
2	04-131	1	ITG RETAINER BUSHING
3	07-088	1	ø11.0xø100.0x3.0 HOPPER SUPPORT WASHER
4	21-036	1	RETAINING RING
5	06-063	10	M10 x 1.5 x 25 HEX HEAD BOLT
6	11-005	14	M10 x 1.5 HEX HEAD NUT
7	07-001	14	ø10 SPLIT TYPE LOCKWASHER
8	07-015	14	ø10 x ø20 x2 FLAT ZINC PLATED WASHER
9	12-048	2	ø2 HAIR PIN
10	12-050	2	COTTER PIN
11	19-291	4	ITG SPREADER DISTRIBUTOR VANE
12	19-292	1	ITG SPREADER DISC
13	06-096	3	M10x1.5x108.6 HEX BOLT
14	12-055	1	ITG SPREADER SHUTTER ADJUSTMENT PIVOT JOINT
15	06-103	1	ITG SPREADER LEVER, FIXED PIVOT
16	11-045	11	M8 x 1.25 HEX HEAD NUT
17	16-153	1	ITG SPREADER BASE ASSEMBLY
18	19-299	1	ITG SPREADER DIRECTIONAL LEVER
19	19-287	1	ITG SPREADER TIE ROD
20	06-094	1	ITG SPREADER THUMB SCREW
21	19-308	1	ITG SPREADER GAGE POINTER
22	19-307	1	ITG SPREADER THREADED ADJ. BLOCK
23	19-286	1	ITG SPREADER LEVER
24	19-298	1	ITG SPREADER LEVER, RUBBER GRIP
25	16-152	1	ITG SPREADER HOPPER SUPPORT ASSEMBLY
26	19-306	1	ITG SPREADER SPRING
27	11-014	1	M10-DIN-985 NYLON LOCKING NUT
28	06-099	1	M10x1.5x70 HEX BOLT
29	10-129	1	ITG ADJUSTMENT LEVER SPACER
30	06-097	1	M8x.25x50 HEX HEAD BOLT
31	11-046	1	NYLON LOCKING NUT
32	12-049	1	2 ø8 x 40 ROLL PIN
33	19-300	1	ITG SPREADER TOP SHUTTER PLATE (FLOW CONTROL)
34	19-301	1	ITG SPREADER BOTTOM SHUTTER PLATE (DIRECTIONAL)
35	06-095	10	M8x1.25x20 HEX HEAD BOLT
36	07-075	11	ZINC PLATED FLAT WASHER
37	01-429	1	ITG 201 F/G 1:1 - SPREADER DRIVE
38	19-296	1	ITG SPREADER FRONT SHIELD
39	19-294	1	RIGHT SIDE HOPPER SUPPORT ARM
40	19-312	1	LEFT SIDE HOPPER SUPPORT ARM W/ MANUAL HOLDER
41	07-074	1	ø10xø30x3.0 FLAT WASHER



INTERNATIONAL TECHNOLOGY GROUP

ENG. OFFICE:
201 W Trail St.-P.O. Box 1698
Dodge City, KS 67801
Tel: (620) 227-2463
Fax: (620) 227-7215

SALES OFFICE:
5375 Avenida Encinas, Suite F
Carlsbad, CA 92008
Tel: (760) 431-3644
Fax: (760) 431-8889

TITLE ITG SPREADER 500 LITER

PART NUMBER
32-040

SHEET: 4 OF 6

DATE

09-26-06

REFERENCE NUMBER

REVISION

7

DRAWN BY: B.C.P.

SCALE: NTS

APPROVED BY:

DET.	PART NO.	QTY.	DESCRIPTION
42	19-295	1	SINGLE PIECE AGITATOR (SHORT)
43	07-090	1	Ø24.85xØ60.0x3.0 NYLON WAHSER
44	19-398	1	ITG SPREADER HOPPER SUPPORT PAN
SPREADER DECALS			
45	19-090	1	THROWN OBJECT WARNING DECAL
46	13-080	1	SIZE DECAL (500)
47	13-082	1	DIRECTIONAL DECAL
48	13-079	1	SPINNER WARNING DECAL
49	13-014	1	DRIVE SHAFT WARNING DECAL
50	13-084	1	GAGE DECAL
51	13-078	1	WARNING DECAL

OPTIONAL ITG SPREADER PARTS

OPTIONAL SINGLE PIECE AGITATORS			
52	19-290	1	SINGLE PIECE EXTENDED AGITATOR (LONG)
OPTIONAL MANUAL HOLDER AND HARDWARE			
53	11-045	2	M8x1.25 HEX NUT
54	01-473	1	ITG MINI MANUAL HOLDER
55	06-095	2	M8x1.25x20 HEX HEAD BOLT
56	07-075	2	ZINC PLATED FLAT WASHER
OPTIONAL STAINLESS STEEL SHUTTERS			
57	19-284	1	ITG SPREADER TOP SHUTTER PLATE-STAINLESS STEEL
58	19-288	1	ITG SPREADER BOTTOM SHUTTER PLATE-STAINLESS STEEL

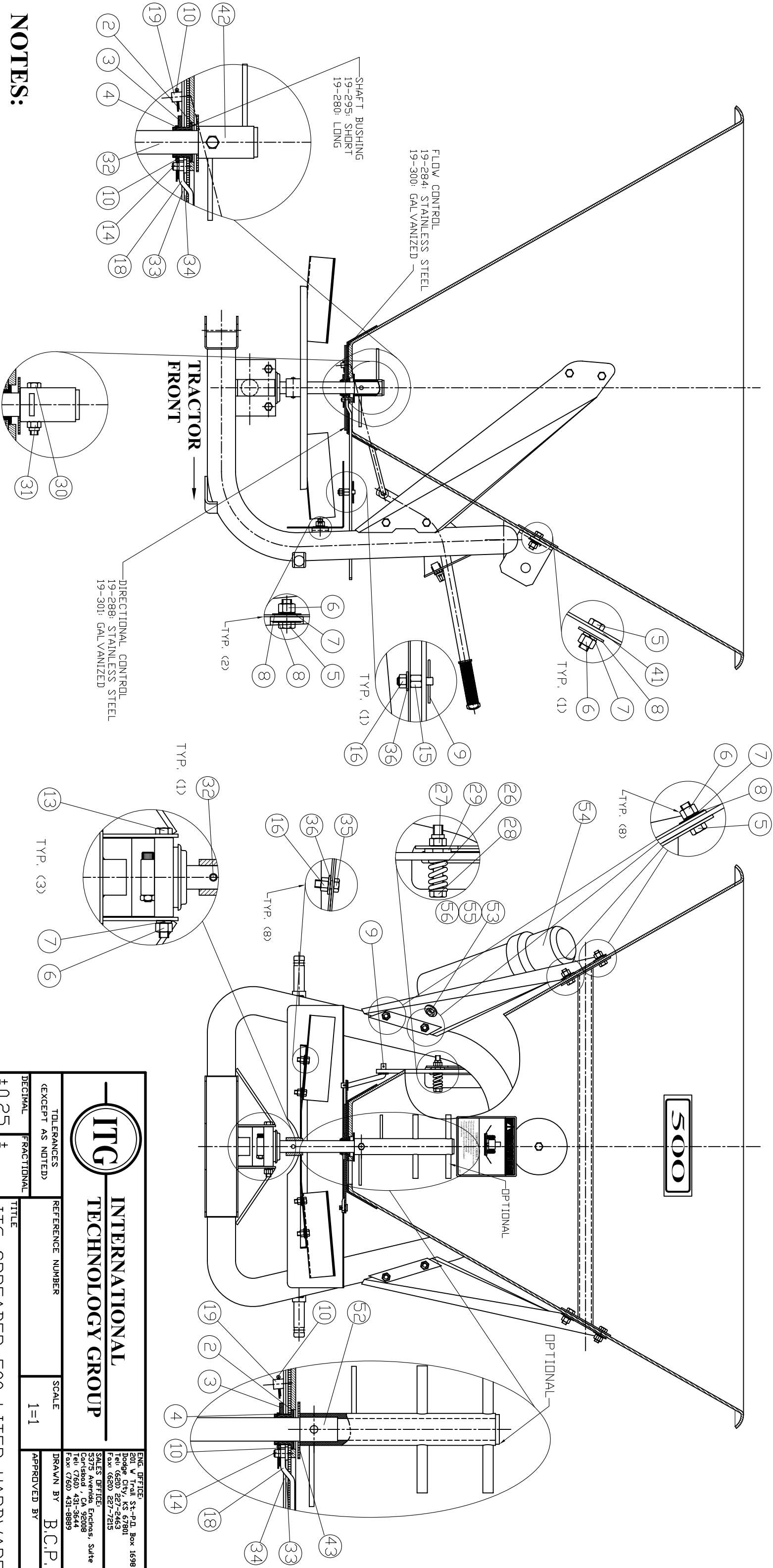

NOTES:

1. MATERIAL:
2. WEIGHT: 45.5 Kg W/D DRIVE LINE

		INTERNATIONAL TECHNOLOGY GROUP		ENG. OFFICE: 201 W. Trail St.-P.O. Box 1698 Joplin, MO 64801 Tel: (620) 257-2463 Fax: (620) 257-7215	
		SALES OFFICE: 5375 Avenida Encinas, Suite F Carlsbad, CA 92008 Tel: (760) 431-3646 Fax: (760) 431-8889		DRAWN BY: B.C.P. APPROVED BY:	
TOLERANCES (EXCEPT AS NOTED) DECIMAL: ±0.25 FRACTIONAL: ±		REFERENCE NUMBER:		SCALE: 1=1	
TITLE: ITG SPREADER 500 LITER-HARDWARE		PART NUMBER: 32-040		REVISION: 7	
DATE: 09-26-06		MACHINE FINISH: 3.2		ANGLUAR: ±	



INTERNATIONAL TECHNOLOGY GROUP

ENG. OFFICE:
201 W Trail St.-P.O. Box 1698
Dodge City, KS 67801
Tel: (620) 227-2463
Fax: (620) 227-7215

SALES OFFICE:
5375 Avenida Encinas, Suite F
Carlsbad, CA 92008
Tel: (760) 431-3644
Fax: (760) 431-8889

TITLE
ITG SPREADER 500 LITER-HARDWARE KIT BAG

PART NUMBER
32-040

SHEET: 6 OF 6

DATE

09-26-06

REFERENCE NUMBER

REVISION

7

DRAWN BY: B.C.P.

SCALE: NTS

APPROVED BY:

ALL ITEMS LISTED BELOW ARE STANDARD ITEMS PACKED IN THE HARDWARE KIT BAG

DET.	PART NO.	QTY.	DESCRIPTION
2	04-131	1	ITG RETAINER BUSHING
3	07-088	1	Ø11.0xØ100.0x3.0 HOPPER SUPPORT WASHER
4	21-036	1	RETAINING RING
5	06-063	10	M10 x 1.5 x 25 HEX HEAD BOLT
6	11-005	14	M10 x 1.5 HEX HEAD NUT
7	07-001	14	Ø10 SPLIT TYPE LOCKWASHER
8	07-015	14	Ø10 x Ø20 x2 FLAT ZINC PLATED WASHER
9	12-048	2	Ø2 HAIR PIN
10	12-050	2	COTTER PIN
11	19-291	4	ITG SPREADER DISTRIBUTOR VANE
14	19-283	1	ITG SPREADER SHUTTER ADJUSTMENT PIVOT JOINT
15	19-282	1	ITG SPREADER LEVER, FIXED PIVOT
16	11-045	11	M8 x 1.25 HEX HEAD NUT
18	12-055	1	ITG SPREADER DIRECTIONAL LEVER
19	06-103	1	ITG SPREADER TIE ROD
20	06-094	1	ITG SPREADER THUMB SCREW
21	19-308	1	ITG SPREADER GAUGE POINTER
22	19-307	1	ITG SPREADER THREADED ADJ. BLOCK
23	19-286	1	ITG SPREADER LEVER
24	19-298	1	ITG SPREADER LEVER, RUBBER GRIP
26	19-306	1	ITG SPREADER SPRING
27	11-014	1	M10-DIN-985 NYLON LOCKING NUT
28	06-099	1	M10x1.5x70 HEX BOLT
29	07-087	1	ITG ADJUSTMENT LEVER FIBER WASHER
30	06-097	1	M8x.25x50 HEX HEAD BOLT
31	11-046	1	NYLON LOCKING NUT
32	12-049	1	2 Ø8 x 40 ROLL PIN
35	06-095	10	M8x1.25x20 HEX HEAD BOLT
36	07-075	11	ZINC PLATED FLAT WASHER
41	07-074	1	Ø10xØ30x3.0 FLAT WASHER
42	19-295	1	SINGLE PIECE AGITATOR (SHORT)
43	07-090	1	Ø24.85xØ60.0x3.0 NYLON WASHER